



Mobile Visitation Station

This unit is specifically built for the environment in which it is meant to reside. The unit is constructed of 13-gauge steel and has a large polycarbonate window that can be left clear or masked to match the size of the viewing opening to the size of the equipment selected. The unit has heavy duty locking casters for easy mobility which means the unit can be easily moved from one area to another and then locked in place when in use or placed in storage.

Louvered panels on the top, bottom and equipment shelf provide air flow through the unit. A removable side panel, along with a removable viewing screen panel, allows access to the equipment. Four tamper proof locks provide security from unauthorized access.

The unit is configurable to provide either hands-free or armored cord handset access. Both options are possible with the proper internal electronic equipment. A special shelf unit on the front provides a place for inmates to sign documents or rest papers or drinks. The base unit comes with powder coated plugs in the mounting holes, so the shelf can be left off or added according to the owner's needs and desires.

Form meets functionality in the Mobile Corrections Video Station. The attention to detail and rugged construction means that you don't have to worry about the unit being destroyed in normal use. Welded panels and heavy-duty construction create a unit that can be used for years to come.

Specifications

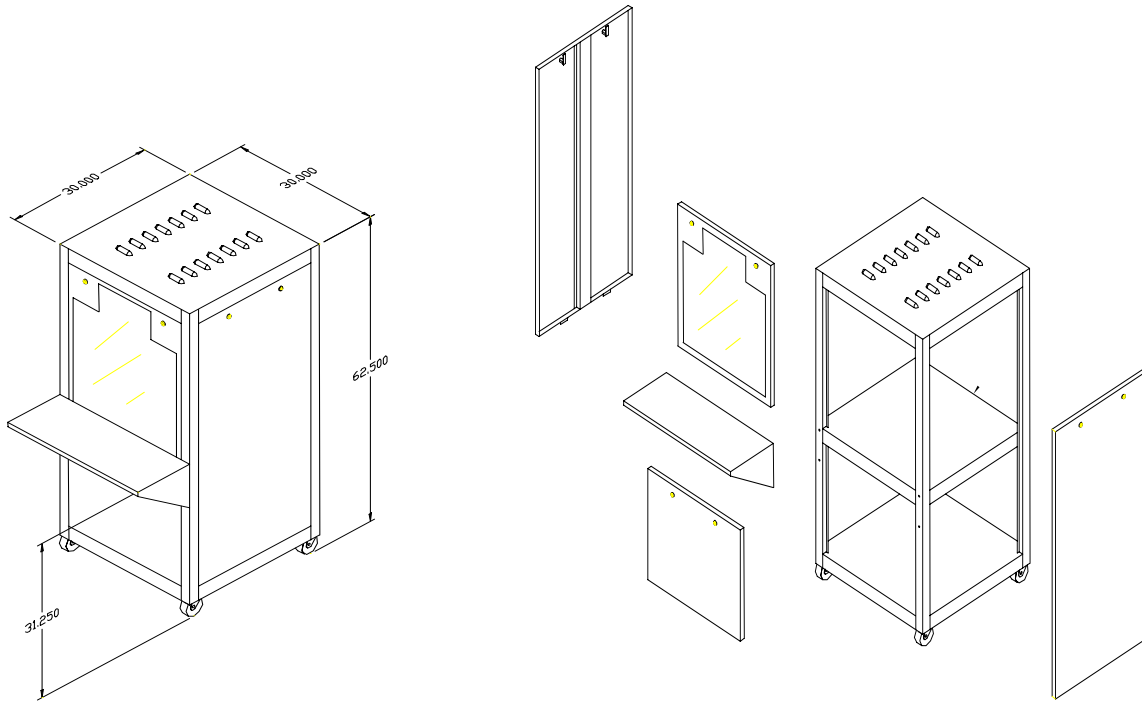

Camera and Monitor not included. Actual unit may vary from unit shown due to engineering changes.

Cabinet Specifications:

- Exterior: 30"W x 62.5"H x 30"D
- Interior: 24"W x 56.5"H x 24"D
- Recessed power and network connections on back

Center Shelf:

- 24" x 24" shelf used to hold visitation equipment.
- 1.5" Opening at back and sides for air circulation and wiring access.

Upper Door:

- Fitted with a 3/8" thick piece of unbreakable lexan. And secured by two locks. Lexan cut-out to fit a camera on a large screen monitor.

Lower Door:

- Removable bottom panel and secured by two locks

Side Panels:

- Body comes with louvered top for ventilation.
- Removable side panels secured by two locks

Wheels:

- 4" Diameter heavy duty casters

Attached work surface:

- 30"W x 12" D

Strike
Industries, Inc.

PO Box 820213 · South Florida · Florida 33082-0213
Phone: 954-567-3420 · Email strike@strikeind.com